

Arrhythmia Classification using the RR-Interval Duration Signal

MG Tsipouras¹, DI Fotiadis¹, D Sideris²

¹Unit of Medical Technology and Intelligent Information Systems, Dept of Computer Science, University of Ioannina and Biomedical Research Institute – FORTH, Ioannina, Greece

²Division of Cardiology, Medical School, University of Ioannina, Ioannina, Greece

Abstract

In this paper we explore the RR-interval duration signal in classifying arrhythmias. Initially the RR-interval duration signal is extracted from the ECGs. Each RR interval is characterized using the MIT-BIH arrhythmia database annotation. We use a 3 RR interval sliding window, centered in the middle RR interval, to classify each beat using a rule-based approach. The rules are obtained from cardiologists and are related to the tachogram morphology in arrhythmic events. Classification is performed for five categories of arrhythmic beats.

The classification system is tested using selected beats from the MIT-BIH database (30,000 annotated beats were used). We present results in terms of sensitivity, positive prediction and system's performance. The scores achieved indicate high performance (95.85%) for the classification of the different categories of arrhythmic beats.

1. Introduction

Arrhythmia is a collective term for any cardiac rhythm, which deviates from the normal sinus rhythm. Arrhythmia may be due to a disturbance in impulse formation or conduction, or both, but it is not always an irregular heart activity [1]. Respiratory sinus arrhythmia is a natural periodic variation in RR intervals, corresponding to respiratory activity [2,3].

The detection of abnormal cardiac rhythms and automatic discrimination from the normal heart activity became an important task in clinical reasons. Several detection algorithms have been proposed such as the sequential hypothesis testing [4], the threshold-crossing intervals [5], algorithms based on neural-networks [6,7,10], time-frequency analysis [8], wavelets [9], complexity measure [11] and multifractal analysis [12].

The classification of detected arrhythmias is also a research field of great interest. Several classification approaches have been presented in the literature:

multiway sequential hypothesis testing [13], fuzzy ARTMAP [15], wavelet analysis combined with radial basis function neural networks [14], algorithms based on neural-networks [16,17] and non-linear dynamical modeling [18].

In this paper we explore the RR interval duration signal in order to classify arrhythmic beats in five arrhythmia categories. Initially, QRS detection is performed on the ECGs and the RR interval duration signal is constructed. Next, a rule-based system is used for the classification. The system is using a 3 RR interval sliding window for the classification of the middle beat. Arrhythmia categories are defined based on the beat annotations in MIT-BIH database (normal beats, atrial, nodal and supraventricular premature beats, ventricular premature beats, escape beats and ventricular flutter/fibrillation beats).

2. Materials and methods

The proposed method consists of two stages, the preprocessing stage and the classification stage.

In the preprocessing stage we analyze the ECG signal to detect the QRS complexes. Then the RR-interval duration signal is constructed.

Table 1. Beat annotation for each classification category.

Category	Beat Annotations	Description
1	N, P, f, p, Q, , +, s, t, ~, L, R	normal beats
2	A, a, J, S	atrial, nodal and supraventricular premature beats
3	V, F	ventricular premature beats
4	e, j, n, E	escape beats
5	[, !,]	ventricular flutter-fibrillation beats

In the classification stage, arrhythmia beat-by-beat classification is performed, using a set of rules. The rules are based on tachogram observations in arrhythmic events and they are applied on a 3 RR interval duration sliding window. Classification is performed for five categories of beats, which are created using the MIT-BIH arrhythmia database annotation [19,20]. Classification categories and the annotations of the beats for each category are given in Table 1.

The rule-based system is based on rules for the discrimination of categories 2, 3, 4 and 5. The first category is recognized if no other rule is applied. This means that the middle beat of the window is considered a-priori normal (category 1) and that changes if the window matches with one of the rules. The algorithm follows:

1. Insert window i , which contains the $RR1_i$, $RR2_i$ and $RR3_i$ intervals
2. $RR2_i$ is classified in category 1.
3. If $RR2_i < 0.6$ sec and $RR2_i < RR3_i$ then $RR2_i$ is classified in category 5.
 - a. $RR2_i$ of all windows following i ($i+1, i+2, \dots, i+n$) that the duration of all intervals are less than 0.8 sec ($RR1_i < 0.8$ and $RR2_i < 0.8$ and $RR3_i < 0.8$) or the total duration of the window is less than 1.8 sec ($RR1_i + RR2_i + RR3_i < 1.8$) are classified in category 5.
 - b. If the total number of intervals that are continually classified in category 5 are less than 4 ($n+1 < 4$) then they all classified in category 1 and the system continue from the window i from step 4.
4. If $RR2_i < a*RR1_i$ and $RR1_i < b*RR3_i$ then:
 - a. If $RR2_i + RR3_i < 2*RR1_i$ then $RR2_i$ is classified in category 2
 - b. Else $RR2_i$ is classified in category 3
5. If $RR2_i > c*RR1_i$ then $RR2_i$ is recognized as category 4
6. Update window ($i = i + 1$) and go to step 1

Parameters a , b and c were initially chosen as 1.0. Experimental results indicated that the algorithm performed better for 0.9, 0.9 and 1.5 respectively. A schematic of the classification algorithm is shown in Figure 1. The proposed method is evaluated using the MIT-BIH arrhythmia database. Initially the method proposed in [21] is used to identify arrhythmic segments as shortly described below:

The RR-interval duration signal is segmented in segments of 32 RR intervals. Each segment is characterized using the MIT-BIH annotation. RR intervals with annotation N, P, f, p, Q, |, +, s, t and ~ were characterized as “Normal” and RR intervals with annotation L, R, A, a, J, S, V, F, [, ! ,], e, j, n and E were characterized as “Arrhythmic”. A segment is

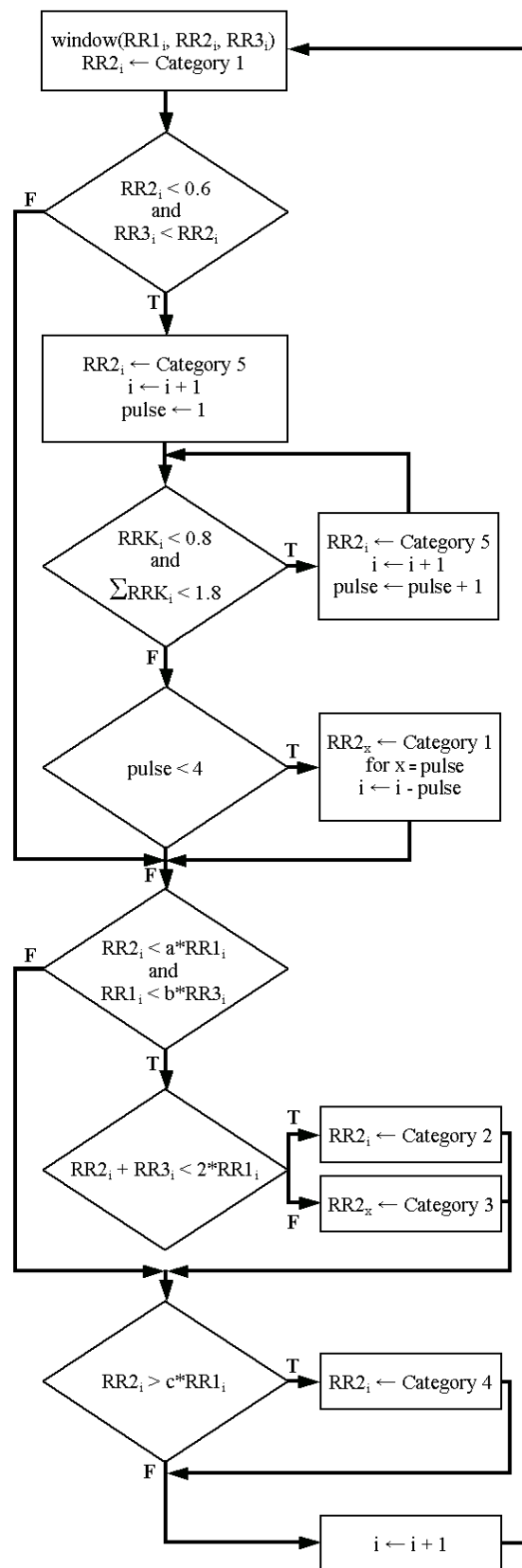

Figure 1. Classification algorithm.

characterized “Normal” if it contains more than 95% “Normal” RR intervals of the total 32 RR intervals, otherwise is characterized “Arrhythmic”.

Time-frequency distributions are applied on the segments and several features are extracted from each one. A set of neural networks is trained, one for each distribution. A decision rule that combines the output of all neural networks is used to obtain the final result for each segment.

From the correctly detected arrhythmic segments 800 were used (25.600 beats) and 4.400 beats were selected randomly from the remaining beats. The final dataset used is given in Table 2.

Table 2. Beats from each category used for the testing of the classification algorithm.

Category	Number of beats
1	25,188
2	1,213
3	2,950
4	265
5	384

3. Results

Results were obtained using the dataset given in Table 2. Table 3 presents the results from the classification algorithm. Element (i,j) in the table represents the total number of beats annotated from the database as category j and classified from the classification algorithm as category i.

Table 3. Results from the classification algorithm.

		Database Annotation				
		1	2	3	4	5
Classification	1	24686	134	312	9	3
	2	164	1040	168	1	0
	3	268	37	2467	1	0
	4	65	2	3	254	0
	5	5	0	0	0	381

The sensitivity and positive prediction for each beat category are given as:

$$\text{Sensitivity} = \frac{\# \text{ of beats correctly classified in category}}{\text{total \# of beats classified in category}}$$

$$\text{P. Prediction} = \frac{\# \text{ of beats correctly classified in category}}{\text{total \# of beats in category}}$$

The obtained results in terms of sensitivity and positive prediction are given in Table 4.

Table 4. Sensitivity and positive prediction for each beat category.

Category	Sensitivity	Positive Prediction
1	98.18%	98.01%
2	75.75%	85.74%
3	88.97%	83.63%
4	78.40%	95.85%
5	98.70%	99.22%

The systems total performance was also estimated as follows:

$$\text{T. Performance} = \frac{\sum_{\text{categories}} \text{correctly classified beats}}{\text{Total beats}}$$

which leads to a total system performance 95.85%.

4. Discussion

It is clearly shown in Table 3 that the classification algorithm based on RR-interval duration is very effective on classifying arrhythmic beats. However, in our dataset, the number of normal intervals (25,188 normal beats, almost 84% of the total beat number) was very large compared to the other categories (second category 4%, third 9.8%, fourth 0.9% and fifth 1.28%). The computed performance is high (almost 96%) because the achieved sensitivity and positive prediction are high for the first category (98.18% and 98.01% respectively), compared with the results for the second and the third category (75.75% sensitivity and 85.74% positive prediction for the second category and 88.97% sensitivity and 83.63% positive prediction for the third). In addition, the percentage of beats misclassified as normal in these categories was high (12.88% for the second category and 12.64% the for third), as well as, the false alarms (502 normal beats were classified as arrhythmic).

For category 4 we obtained high positive prediction (95.85%) but low sensitivity (78.40%), which is clearly due to the high number of false alarms (65). For category 5 we obtained the best results, 98.70% for sensitivity and 99.22% for positive prediction, absolute discrimination among the arrhythmia categories and only 5 false alarms and 3 misclassified beats as normal. This is because category 5 contains start, progress and stop of ventricular flutter-fibrillation beats that are easily discriminated in a tachogram due to their high frequency.

5. Conclusions

We have developed a method for arrhythmia beat classification. The method is based on the RR-interval duration signal, extracted from ECGs, and a set of rules to perform beat discrimination for five beat categories, one for normal and four for arrhythmic. The rules were obtained from the experience of cardiologists and they were applied on a 3 RR-interval sliding window, characterizing the middle beat.

The proposed method has been evaluated using a large dataset (30,000 beats), which can be considered very similar to the conditions met in clinical environment. We achieved 95.85% total performance and high discrimination ability among the five categories. The main advantage of the system is that it is completely based on RR-interval duration signal and rules. It uses only QRS detection and not any other time consuming and in most of the cases unreliable ECG processing, such as P wave detection. Due to small processing time, the system can operate in real-time.

References

- [1] Sandoe E, Sigurd B. Arrhythmia - A guide to clinical electrocardiology. Bingen: Publishing Partners Verlags GmbH, 1991.
- [2] Goldberger L, Goldberger E. Clinical Electrocardiography. Saint Louis: The Mosby Company, 1977.
- [3] Sideris DA. Primary Cardiology. Athens: Scientific Editions Grigorios K Parisianos, 1991 (in Greek).
- [4] Thakor NV, Zhu YS, Pan KY. Ventricular tachycardia and fibrillation detection by a sequential hypothesis testing algorithm. *IEEE Trans Biom Eng* 1990;37:837-843.
- [5] Clayton RH, Murray A, Campbell RWF. Comparison of four techniques for recognition of ventricular fibrillation of the surface ECG. *Med Biol Eng Comp* 1993;31:111-117.
- [6] Clayton RH, Murray A, Campbell RWF. Recognition of ventricular fibrillation using neural networks. *Med Biol Eng Comp* 1994;32:217-220.
- [7] Yang TF, Device B, Macfarlane PW. Artificial neural networks for the diagnosis of atrial fibrillation. *Med Biol Eng Comp* 1994;32:615-619.
- [8] Afonso VX, Tompkins WJ. Detecting ventricular fibrillation. *IEEE Eng Med Biol* 1995;14:152-159.
- [9] Khadra L, Al-Fahoum AS, Al-Nashash H. Detection of life-threatening cardiac arrhythmias using wavelet transformation. *Med Biol Eng Comp* 1997;35:626-632.
- [10] Minami K, Nakajima H, Toyoshima T. Real-time discrimination of ventricular tachyarrhythmia with Fourier-transform neural network. *IEEE Trans Biom Eng* 1999;46:179-185.
- [11] Zhang XS, Zhu YS, Thakor NV, Wang ZZ. Detecting ventricular tachycardia and fibrillation by complexity measure. *IEEE Trans Biom Eng* 1999;46:548-555.
- [12] Wang Y, Zhu YS, Thakor NV, Xu YH. A short-time multifractal approach for arrhythmia detection based on fuzzy neural network. *IEEE Trans Biom Eng* 2001;48:989-995.
- [13] Thakor NV, Natarajan A, Tomaselli G. Multiway sequential hypothesis testing for tachyarrhythmia discrimination. *IEEE Trans Biom Eng* 1994;41:480-487.
- [14] Al-Fahoum AS, Howitt I. Combined wavelet transformation and radial basis neural networks for classifying life-threatening cardiac arrhythmias. *Med Biol Eng Comp* 1999;37:566-573.
- [15] Ham FM, Han S. Classification of cardiac arrhythmias using fuzzy ARTMAP. *IEEE Trans Biom Eng* 1996;43:425-430.
- [16] Osowski S, Linh TH. ECG beat recognition using Fuzzy Hybrid Neural Network. 2001;48:1265-1271.
- [17] Docur Z, Olmez T. ECG beat classification by a hybrid neural network. *Comp Meth Prog Biomed* 2001;66:167-181.
- [18] Owis MI, Abou-Zied AH, Youssef AM, Kadah YM. Study of features based on nonlinear dynamical modeling in ECG arrhythmia detection and classification. *IEEE Trans Biom Eng* 2002;49:733-736.
- [19] MIT-BIH Arrhythmia Database CD-ROM. Third Edition, 1997, Harvard-MIT Division of Health Sciences and Technology.
- [20] Moody GB, Mark RG. The impact of the MIT-BIH arrhythmia database. *Comp Biomed Res* 1996;29:174-193.
- [21] Tsipouras MG, Fotiadis DI. Arrhythmia detection with time and time-frequency analysis of heart rate variability. In: Cerutti S, Akay M, Mainardi LT, Sato S, Zywiets C. IV International Workshop on Biosignal Interpretation. Milano, Italy, 2002:175-178.

Address for correspondence.

Markos Tsipouras.
Unit of Medical Technology and Intelligent Information Systems, Dept. of Computer Science, University of Ioannina Campus, P.O. 45110, Ioannina, Greece.
markos@cs.uoi.gr